

Paper ID [A0801]

(Please fill this Paper ID in OMR Sheet)

B.Tech. (Sem. - 3rd)**STRENGTH OF MATERIALS - I (ME - 201)****Time : 03 Hours****Maximum Marks : 60****Instruction to Candidates:**

- 1) Section - A is **Compulsory**.
- 2) Attempt any **Four** questions from Section - B.
- 3) Attempt any **Two** questions from Section - C.

Section - A**Q1)****(10 × 2 = 20)**

- a) Find the ratio of second moment of area about the centroidal axis to the second moment of area about the base of a rectangle with base = 200 mm and depth = 600 mm.
- b) A bar 40 mm in diameter is subjected to an axial load of 40 kN. The extension of the bar over a gauge length of 200 mm is 0.3 mm. The decrease in diameter is 0.018 mm. Find the Poisson's ratio.
- c) A simply supported beam of uniform cross-section is subjected to a maximum bending moment of 22.5 kNm. If its cross-section is a hollow tube with outer diameter 40 mm and inner diameter 20 mm, find the value of maximum bending stress.
- d) A cantilever beam of uniform EI has a span equal to 'L'. An upward force W acts at the midpoint of the beam and a downward force P acts at the free end. In order that the deflection at the free end is zero, find the relation between P and W.
- e) Find the ratio of the torsional moments of resistance of a solid circular shaft of diameter 'D' and a hollow circular shaft having external diameter 'D' and internal diameter 'd'.
- f) A steel bar of 2m length is fixed at both ends at 20°C. If the coefficient of thermal expansion is $11 \times 10^{-6}/^{\circ}\text{C}$ and the modulus of elasticity is 200 GPa, find the stress experienced by the bar if the temperature is reduced to 18°C.
- g) Briefly explain the difference between 'neutral layer' and 'neutral axis'.

- h) A simply supported beam of span L carries a concentrated load W at its mid span. If the width 'b' of the beam is constant throughout the span, what will be the beam's depth at the mid-span if the permissible bending stress is 'f'?
- i) The Euler load for a column is 1000kN and the 'Rankine' load is 600kN. Find the 'crushing' load?
- j) Briefly explain the concept of the point of contra-flexure.

Section - B

(4 × 5 = 20)

Q2) A steel shaft ABCD having a total length of 4.8 m consists of three lengths having different sections as follows

AB	Hollow	$d_o = 12$ cm	$d_i = 10.2$ cm
BC	Solid	$d = 12$ cm	
CD	Solid	$d = 9.6$ cm	

If the angle of twist is same for each section, determine the lengths of each section. Find the value of applied torque and total angle of twist if maximum shear stress in hollow section is limited to 50MPa. $G = 84$ GPa.

- Q3) A cylindrical pressure vessel is fabricated from steel plating that has a thickness of 20mm. The inner diameter of the vessel is 450mm, and its length is 2m. Determine the maximum internal pressure that can be applied if the longitudinal stress is limited to 140MPa and the circumferential stress is limited to 60MPa.
- Q4) A 2m long pin ended column of square cross-section is to be made of wood. Assuming $E = 13$ GPa, $\sigma_{\text{allow}} = 12$ MPa, and using a factor of safety of 2.5 in computing the Euler's critical load for buckling, determine the size of the cross section if the column is to safely support (a) a 100 kN load.
- Q5) A cantilever beam of span 3 m is loaded with a concentrated load of 500 N at the free end and a load W at the mid span. Determine the value of W so that the deflection at the free end is 10 mm. Take $E = 15$ GPa, and $I = 10^7$ mm⁴.
- Q6) A cast iron pipe having a bore of 60 cm and wall thickness 4 cm is simply supported over a span of 4 m. Find the intensity of maximum bending stress when it is full of water. Density of cast iron = 70 kN/m³ and density of water = 10 kN/m³.

Section - C

(2 × 10 = 20)

Q7) The aluminum and bronze cylinders are centered and secured between two rigid end plates by tightening the two steel bolts, as shown in Fig.1. There is no axial load in the assembly at 50° F. Find the stress in the steel bolts when the temperature is increased to 200° F. Use the following data

	A (mm ²)	α (/°F)	E(GPa)
Aluminium Cylinder	1290	12.8×10^{-6}	70
Bronze Cylinder	1935	10.5×10^{-6}	83
Each steel bolt	485	6.5×10^{-6}	200

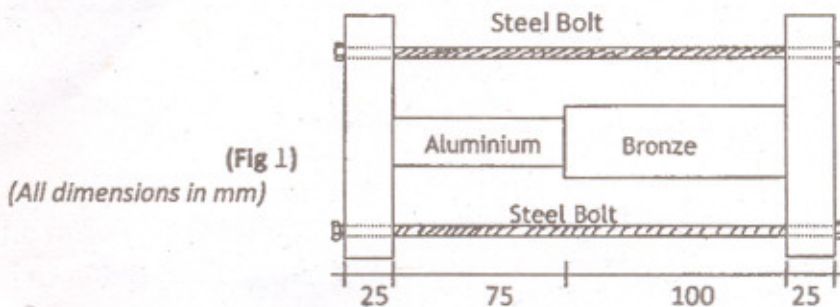

Q8) Direct stresses of 160 MPa tensile and 120 MPa compressive exist on two perpendicular planes at a certain point in a body. They are also accompanied by shear stresses on the planes. The greatest principal stress at the point due to these is 200 MPa.

- What must be the magnitude of the shearing stresses on the two planes?
- What will be the maximum shearing stress and the associated normal stress at the point?

Use the Mohr's circle approach. Show the results on properly oriented elements.

Q9) A 5 m long cantilever beam is subjected to a uniformly distributed load of 2kN/m spread over the second half of the beam, extending up to the free end. A counter-clockwise concentrated moment of 10kNm also acts at the middle of the beam. Plot the shear force and bending moment diagram for the beam. Clearly show on the diagram the points of contra-flexure, if any.

